

## Solenoid DCV Cover-

Model: CVC-\*\*- DE  
Pressure : 420 bar

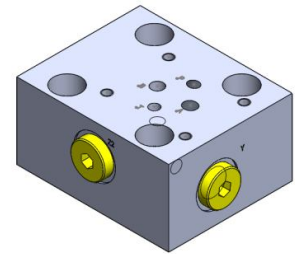

### Hydraulic symbol

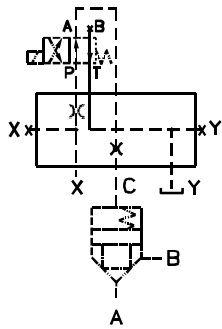

CVC\*DEA\*

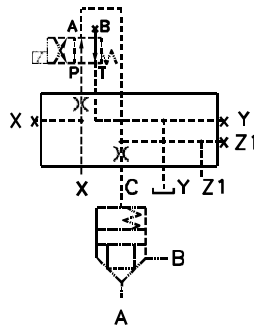

CVC\*DEA-AZ1\*

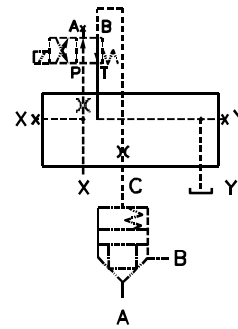

CVC\*DEB\*

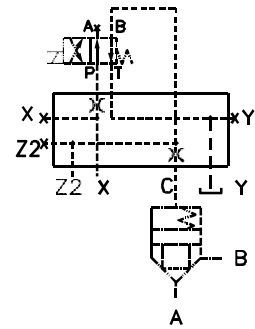

CVC\*DEB-BZ2\*

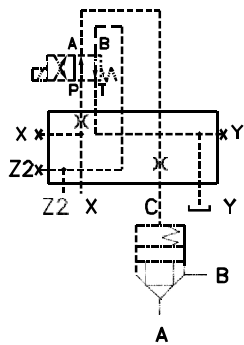

CVC\*DEA-BZ2\*

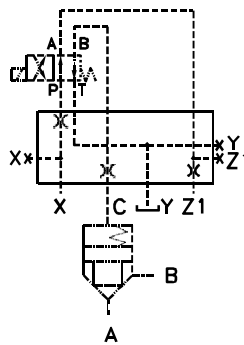

CVC\*DEB-AZ1\*

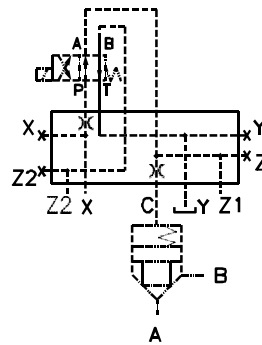

CVC\*DEA-AZ1-BZ2\*

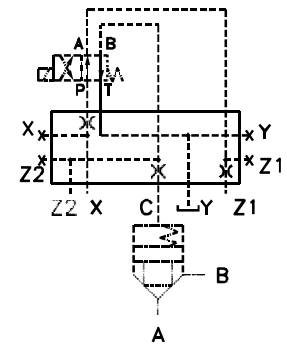

CVC\*DEB-AZ1-BZ2\*

### Ordering code

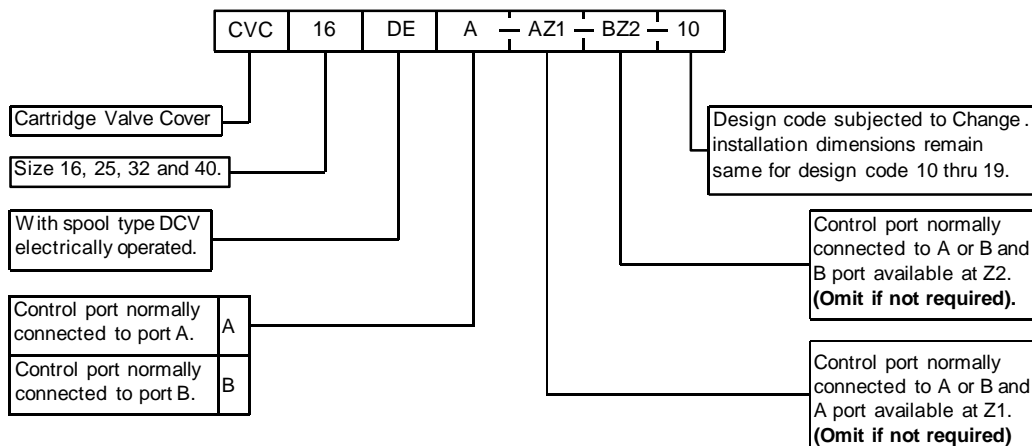

**Installation Dimensions:**

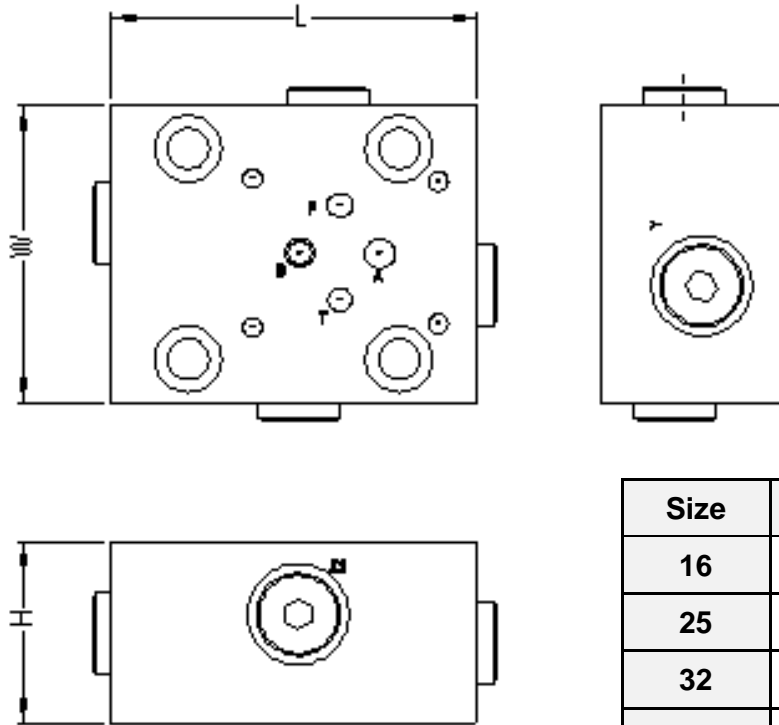

Size	H	W	L
16	40	65	80
25	40	85	85
32	50	102	102
40	60	125	125

Size	Mass Kg. Apprx	*M. 4 nos. Cover fixing S.H.C. Screw (Class 12.9)	Tightening Torque.
16	2.0	M8 x 40 Long	39 Nm
25	2.2	M12 x 45 Long	135 Nm
32	4.1	M16 x 55 Long	330 Nm
40	7.4	M20 x 70 Long	650 Nm